

Part # 1016764
 QC - Canoe / Kayak Rack (Pair)



1. Attach QC accessory bracket to QC vertical bumper bracket weldment using hardware from QC accessory bracket 3/8 x 1 carriage bolts and 3/8 flange nuts.
2. Attach QC vertical bumper bracket to slider leg (at desired height) using 3/8 x 1 carriage bolts and 3/8 flange nuts.
3. Attach QC canoe / kayak rack arm to slider leg using 3/8 x 1 carriage bolts and 3/8 flange nuts (set to desired height before tightening nuts).
4. Slide the caps onto top and bottom of slider leg and on end of QC canoe / kayak rack arm.
5. Attach QC canoe / kayak rack to dock using accessory bracket, space racks apart so the racks are towards the end of the canoe or kayak.

Note: Use a bungee cord to secure canoe or kayak to rack. Use the holes in the bottom of QC canoe / kayak rack arm to secure the bungee cord.

Note: Arm is 32" long and has about 36" of vertical adjustment.

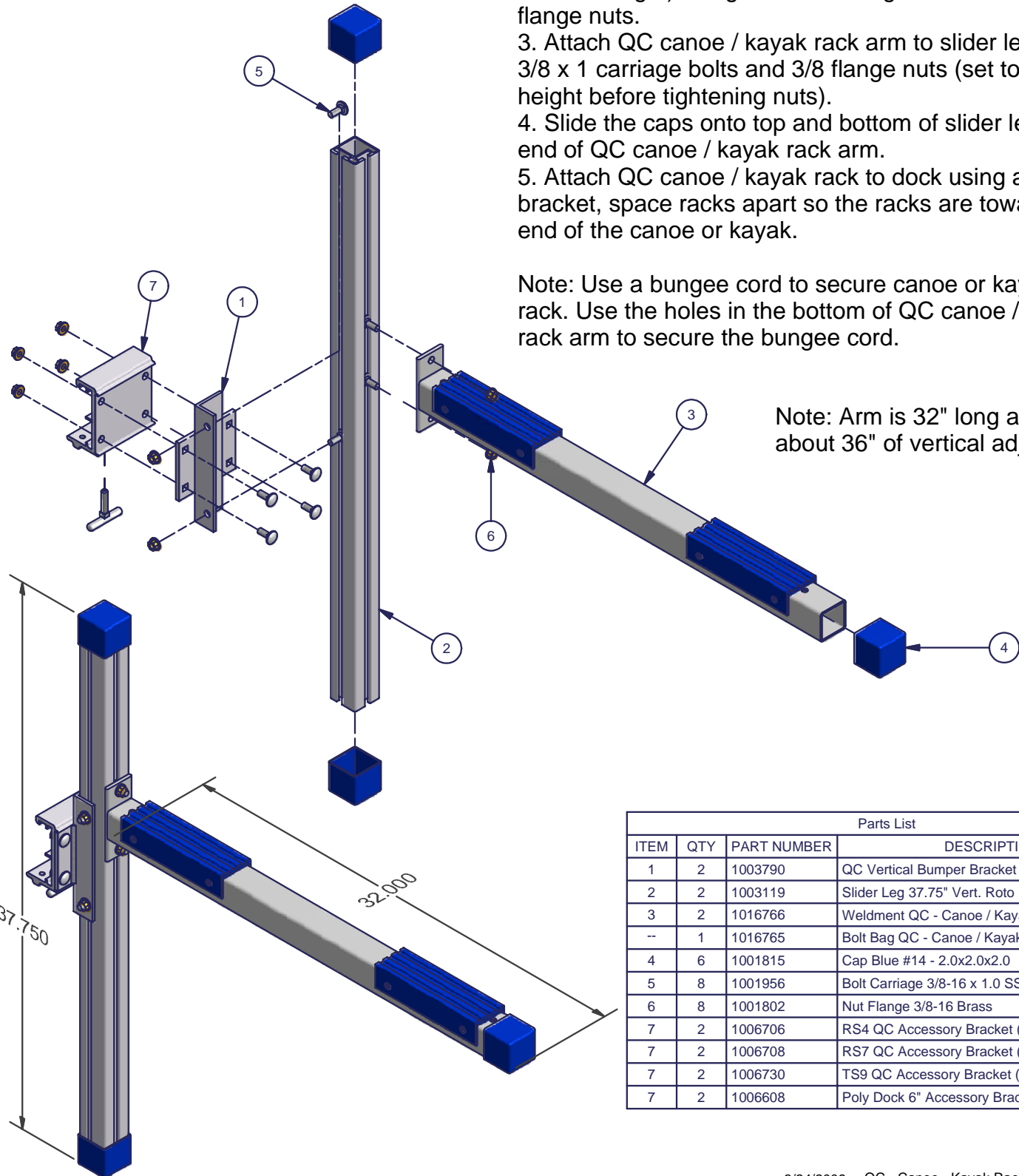

Parts List			
ITEM	QTY	PART NUMBER	DESCRIPTION
1	2	1003790	QC Vertical Bumper Bracket Weldment
2	2	1003119	Slider Leg 37.75" Vert. Roto Bumper
3	2	1016766	Weldment QC - Canoe / Kayak Rack Arm
--	1	1016765	Bolt Bag QC - Canoe / Kayak Rack
4	6	1001815	Cap Blue #14 - 2.0x2.0x2.0
5	8	1001956	Bolt Carriage 3/8-16 x 1.0 SS 304
6	8	1001802	Nut Flange 3/8-16 Brass
7	2	1006706	RS4 QC Accessory Bracket (sold separate)
7	2	1006708	RS7 QC Accessory Bracket (sold separate)
7	2	1006730	TS9 QC Accessory Bracket (sold separate)
7	2	1006608	Poly Dock 6" Accessory Bracket (sold separate)